

SERVICE BULLETIN

Replacement of circlip (carburetor) for ROTAX® Engine Type 912 and 914 (Series)

ATA System: 73-00-00 Fuel system

MANDATORY

1) Planning information

To obtain satisfactory results, procedures specified in this publication must be accomplished with accepted methods in accordance with prevailing legal regulations.

BRP-Rotax GmbH & Co KG cannot accept any responsibility for the quality of work performed in accomplishing the requirements of this publication.

1.1) Applicability

All versions of ROTAX® engine types 912 and 914 Series are affected if at least one of the following criteria applies:

Criterion A) Engine serial number:

Engine type	Serial number
912 A	from S/N 4411057 up to S/N 4411621 inclusive
912 F	from S/N 4413045 up to S/N 4413165 inclusive
912 S	from S/N 4924905 up to S/N 4925000 inclusive from S/N 9139001 up to S/N 9139252 inclusive from S/N 9563601 up to S/N 9565000 inclusive
914 F	from S/N 4421422 up to S/N 4422113 inclusive from S/N 4422115 up to S/N 4422124 inclusive

NOTE: Engine with S/N higher than the range listed above, have already been inspected during serial production and are equipped with the carburetor circlip part no. 945786.

Criterion B) Carburetors:

The part numbers and serial numbers of the carburetors:

Carburetors	Carburetors part no.	Serial number
912 A/F	1/3 part no. 892500 2/4 part no. 892505	from S/N 144628 up to S/N 190938 inclusive from S/N 144589 up to S/N 190858 inclusive
912 S	1/3 part no. 892530 2/4 part no. 892535	from S/N 145021 up to S/N 191489 inclusive / from S/N 191491 up to S/N 191496 inclusive / from S/N 191498 up to S/N 191499 inclusive / from S/N 191502 up to S/N 191513 inclusive / SN 191515 / S/N 191517 from S/N 144903 up to S/N 191601 inclusive / from S/N 191603 up to S/N 191617 inclusive / from S/N 191631 up to S/N 191637 inclusive /

PRELIMINARY

d06767.fm

SERVICE BULLETIN

914 F	1/3 part no. 892520	from S/N 143849 up to S/N 190436 inclusive / from S/N 190438 up to S/N 190662 inclusive / from S/N 190664 up to S/N 190864 inclusive / from S/N 190866 up to S/N 190877 inclusive / from S/N 190879 up to S/N 190885 inclusive / from S/N 190887 up to S/N 190890 inclusive / S/N 190897 / S/N 190903 / S/N 190906 / S/N 190908
	2/4 part no. 892525	from S/N 144003 up to S/N 185713 inclusive / from S/N 185715 up to S/N 190359 inclusive / from S/N 190361 up to S/N 190705 inclusive / from S/N 190712 up to S/N 190740 inclusive / from S/N 190742 up to S/N 190746 inclusive / from S/N 190748 up to S/N 191408 inclusive / from S/N 191418 up to S/N 191422 inclusive / S/N 191424 / from S/N 191426 up to S/N 191427 inclusive / S/N 191439 inclusive

NOTE: Carburetors with S/N higher than the range listed above, have already been inspected during serial production and are equipped with the carburetor circlip part no. 945786.

Criterion C) Spare parts:

Further all engines are affected, which have been equipped with carburetors with part number and serial number listed within Criterion B) above during engine repair, maintenance or general overhaul or any other exchange action.

Further all engines are affected, which have been equipped with circlip part no. 945785 as a spare part or provided within a service kit carburetor, maintenance kit carburetor and overhaul kits during engine repair, maintenance or general overhaul or any other exchange action.

1.2) Concurrent ASB/SB/SI and SL

None.

1.3) Reason

Due to deviations in the manufacturing process a partial fracture of the circlip may occur. This fracture might lead to a crack/ total fracture of the circlip which in consequence may lead to a malfunction of the carburetor. Possible effects might be rough engine running or an unusual engine operating behavior.

1.4) Subject

Replacement of circlip (carburetor) for ROTAX® engine type 912 and 914 (Series).

1.5) Compliance

- Immediately, on uninstalled engines / spare parts
- Within the next 25 hours of operation, but at the latest by July 31st 2020 the inspection and mandatory exchange of the circlip must be conducted according to the following instructions in Chapter 3

⚠ WARNING Non-compliance with these instructions could result in engine damages, personal injuries or death.

d06767.fm

PRELIMINARY

SERVICE BULLETIN

1.6) Approval

The technical content of this document is approved under the authority of DOA ref. EASA.21J.048.

1.7) Labor time and credit

A labor credit will be provided for work performed by a technician with current and applicable iRMT rating.

Work performed	iRMT rating required	Labor credit
Disassembly, replacement of parts, re-assembly, test run and logbook entry as per Chapter 3 (per engine)	iRMT Maintenance Heavy	1.10 h

To apply for labor credit, contact your ROTAX® Authorized Distributor or their independent Service Centers.

1.8) Mass data

Change of weight - - - none.
 Moment of inertia - - - unaffected.

1.9) Electrical load data

No change.

1.10) Software modifications

No change.

1.11) References

In addition to this technical information refer to current issue of

- Illustrated Parts Catalog (IPC)
- Maintenance Manual Line (MML)
- Maintenance Manual Heavy (MMH)

NOTE: The status of the Manuals can be determined by checking the table of amendments. The 1st column of this table shows the revision status. Compare this number to the one listed on the ROTAX website: www.flyrotax.com. Updates and current revisions can be downloaded for free.

1.12) Other Publications affected

None.

1.13) Interchangeability of parts

- All used parts and affected circlips part no. 945785 are unserviceable and must be scrapped

NOTE: For carburetors, service kits carburetor, maintenance kit carburetor, overhaul kit etc. replace affected circlip part no. 945785 with circlip part no. 945876.

PRELIMINARY

d06767.fm

SERVICE BULLETIN

2) Material Information

2.1) Material

Price and availability will be provided on request by ROTAX® Authorized Distributors or their independent Service Centers.

2.2) Company support information

- Any possible support by BRP-Rotax will be provided on request by ROTAX® Authorized Distributors or their independent Service Centers
- Shipping costs, downtime costs, loss of income, telephone costs etc. or costs of conversion to other engine versions or additional work, as for instance simultaneous engine overhauls are not covered in this scope and will not be borne or reimbursed by ROTAX®

2.3) Material requirement and credit per engine

Parts requirement:

Fig.no.	Part number	Qty/engine	Description	Old p/n	Application
5	945786	2	Circlip	945785	Carburetor jet needle
5	950430	2	O-ring	-	Carburetor jet needle
9	230150	4	Gasket ring 10x14	-	For Engine Type 914 only: Fuel hose assy.

2.4) Material requirement and credit per spare part

None.

2.5) Rework of parts

None.

2.6) Special tooling/lubricants- /adhesives- /sealing compounds

Price and availability will be supplied on request by ROTAX® Authorized Distributors or their independent Service Centers:

Description	Qty/engine	Part no.	Application
LOCTITE 243 BLUE	as required	897651	Fixation screw

NOTICE

If using these special tools observe the manufacturers specifications.

SERVICE BULLETIN

3) Accomplishment/Instructions

- ROTAX® reserves the right to make any amendments to existing documents, which might become necessary due to this standardization, at the time of next revision or issue.

NOTE: Before maintenance, review the entire documentation to make sure you have a complete understanding of the procedure and requirements.

Accomplishment

All measures must be implemented and confirmed by at least one of the following persons or organizations:

- ROTAX® - Airworthiness representatives
- ROTAX® - Authorized Distributors or their independent Service Centers
- Persons approved by the respective Aviation Authorities
- Persons with approved qualifications for the corresponding engine types. Only authorized persons (iRMT, Level Heavy Maintenance) are entitled to carry out this work
- Persons with type-specific training

NOTE: Indicates supplementary information which may be needed to fully complete or understand an instruction.



All work has to be performed in accordance with the relevant Maintenance Manuals (Line/Heavy).

3.1) General

Step	Procedure
1	Check the criteria given on page 1, section 1.1, if the aircraft engine is affected by this SB.
2	Check the engine logbook and maintenance documentation, if this SB has already been accomplished.

PRELIMINARY

d06767.fm

SERVICE BULLETIN

3.2) Instructions

3.2.1) Disassembly

To replace the circlip and O-ring, the following steps are necessary:

See Fig. 1.

Step	Procedure
1	Unclamp the return spring (1).

1 Return spring

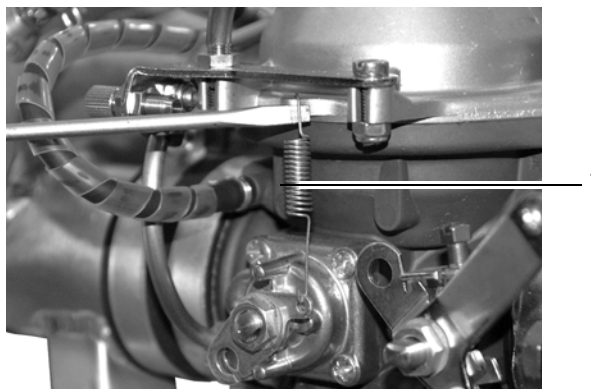

Fig. 1

010217

See Fig. 3.

Step	Procedure
2	For engine type 914 Series only: Remove the 2 fuel lines (2) to the fuel pressure regulator by removing banjo bolts M10 (3) and sealing rings 10x14 (4) on both sides. Remove cable clamp (5), release lock nut M5 (6) and take off the fuel lines.

- 2 Fuel lines
- 3 Banjo bolts
- 4 Sealing ring
- 5 Cable clamp
- 6 Lock nut M5

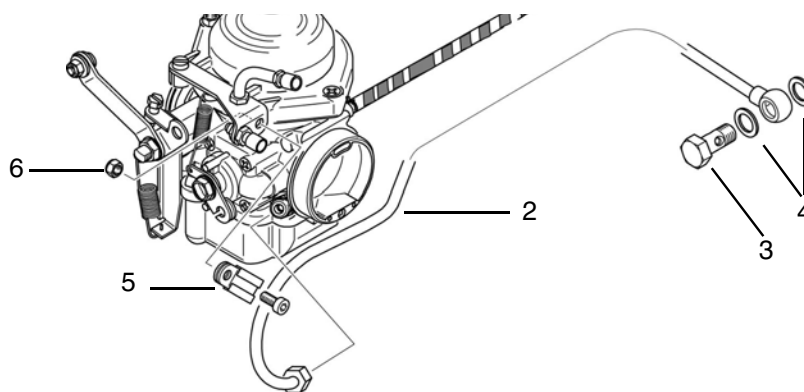

Fig. 2

Engine type 914 Series

AE_912_0216

d06767.fm

PRELIMINARY

SERVICE BULLETIN

See Fig. 3

Step	Procedure
3	Remove countersunk screw M5x12 (7) and oval head screw M5x20 (8) with distance sleeve (9).

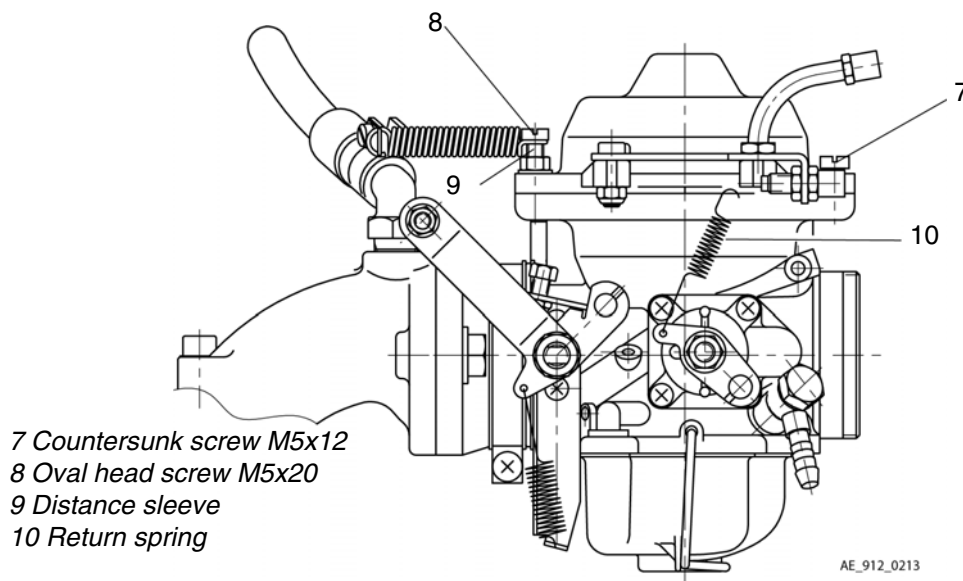

Fig. 3

See Fig. 4.

Step	Procedure
4	Lift chamber top (11) from carburetor. Remove throttle valve spring (12) and pull carburetor piston assy. (13) from carburetor.

NOTICE Fixation screw is held in place with LOCTITE 243. Make sure to use proper size of screw driver to not damage the aluminum fixation screw! Heat may be applied to the piston to aid removal.

Step	Procedure
5	Remove fixation screw (14) from piston.

PRELIMINARY

d06767.fm

SERVICE BULLETIN

PRELIMINARY

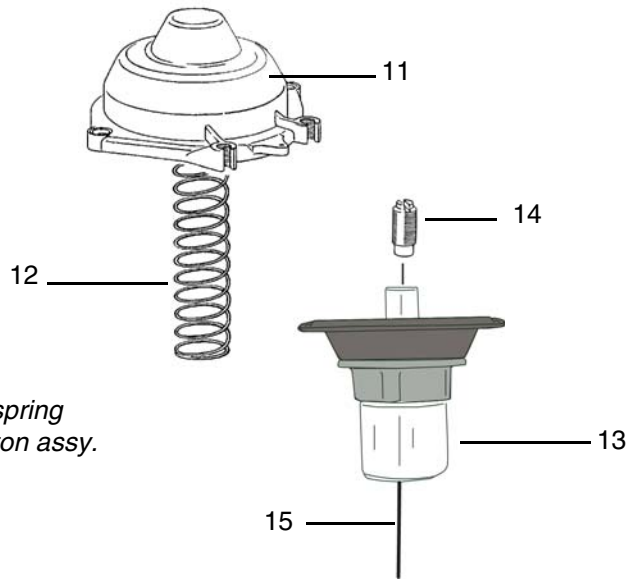

- 11 Chamber top
- 12 Throttle valve spring
- 13 Carburetor piston assy.
- 14 Fixation screw
- 15 Jet needle

Fig. 4

AE_912_0210

See Fig. 5.

Step	Procedure
6	Remove jet needle (15) with circlip and O-ring from piston assy. (13).
7	Remove original O-ring (17) and circlip (16) from the jet needle (15) and discard. NOTE: Take note of the circlip's original needle position.

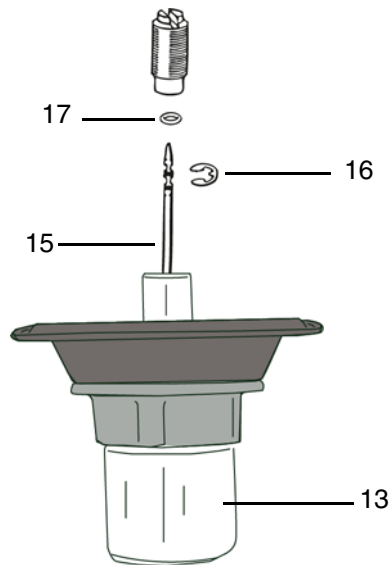

- 13 Carburetor piston assy.
- 15 Jet needle
- 16 Circlip
- 17 O-ring 2.5x1.5

Fig. 5

AE_912_0211

d06767.fm

SERVICE BULLETIN

3.2.2) Assembly

See Fig. 6.

Step	Procedure
1	Place a new circlip part no. 945786 (1) into the same needle position. Place a new O-ring 2.5x1 part no. 950430 (2) over the jet needle (3).

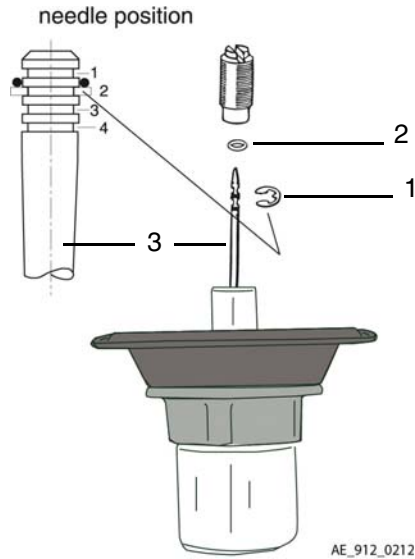

- 1 Circlip
- 2 O-ring 2.5x1
- 3 Jet needle

Fig. 6

See Fig. 7.

Step	Procedure
2	Place the jet needle assy. (3) into the carburetor piston (4) so that the needle protrudes through the piston.
3	Fix the fixation screw (5) with a small amount of LOCTITE 243 and tighten in place. NOTE: The jet needle is held in position by the circlip and its movement is dampened by the O-ring.
4	Place the piston assy. (4) into the carburetor body. The diaphragm's alignment tab (6) must be seated within the carburetor body recess (7).

d06767.fm

PRELIMINARY

SERVICE BULLETIN

PRELIMINARY

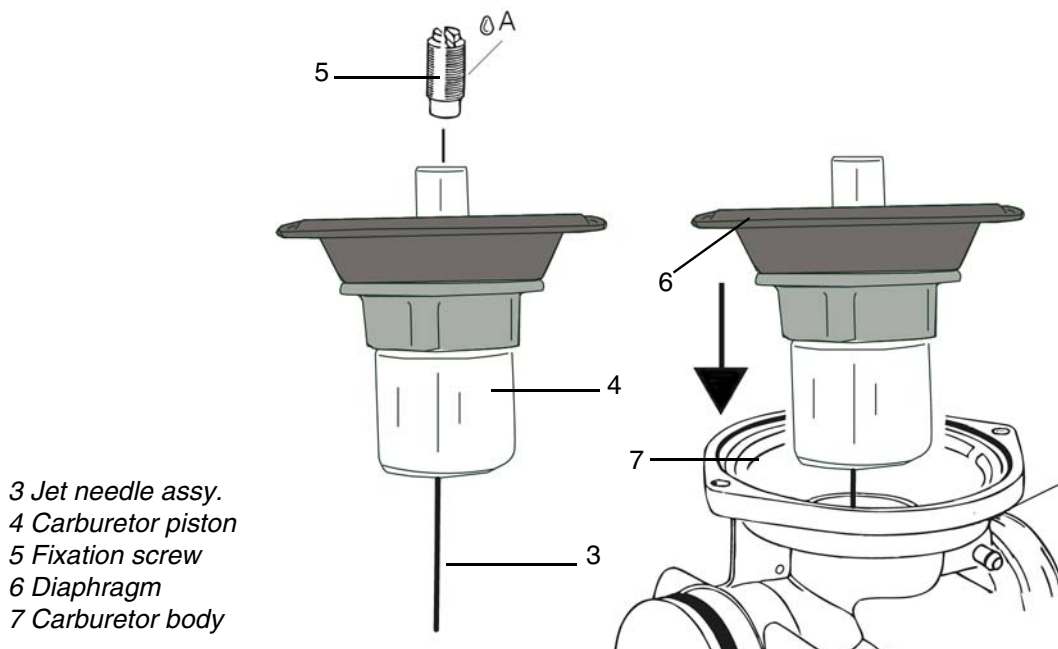

Fig. 7

AE_912_0214

See Fig. 8.

Step	Procedure
5	Place the throttle valve spring (8) into the piston and attach the chamber top (9) with countersunk screw M5x12 (10) and oval head screw M5x20 (11) with distance sleeve (12). NOTE: The piston assy. must remain aligned. Avoid rotating the chamber top while attaching screw.
6	Mount the return spring (13) again.

SERVICE BULLETIN

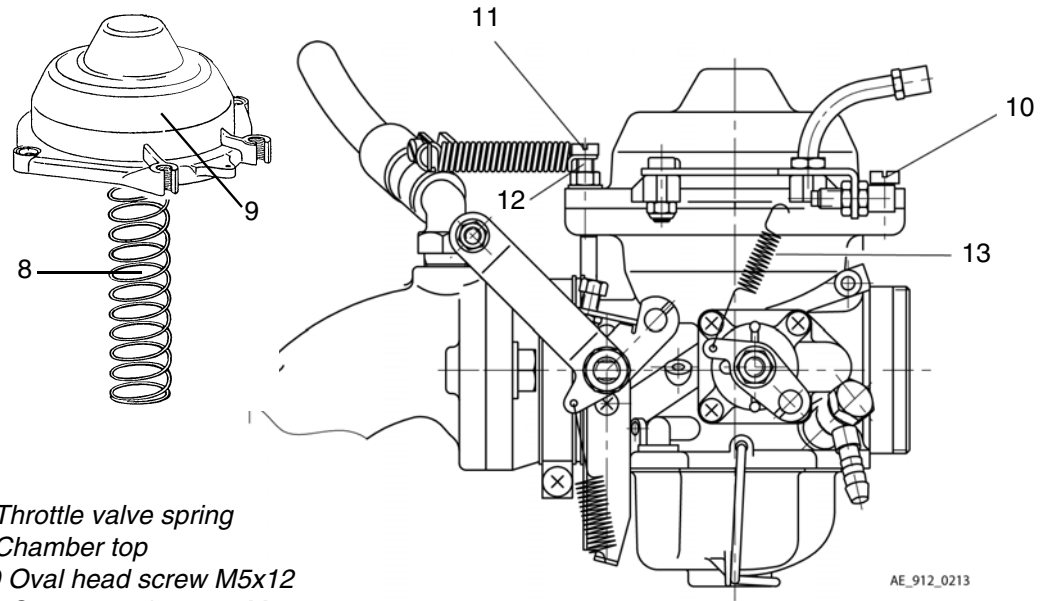

- 8 Throttle valve spring
- 9 Chamber top
- 10 Oval head screw M5x12
- 11 Countersunk screw M5x20
- 12 Distance sleeve
- 13 Return spring

Fig. 8

See Fig. 9.

Step	Procedure
7	For engine type 914 Series only: Attach fuel line (14) to carburetor (fuel inlet). Support the line on the carburetor bracket with a cable clamp (16). The cable clamps are attached with Allen screw (17) M5x12 and new lock nut M5 (15). The tighten lock nut M5 to 10 Nm (90 in.lb). Attach the 2 fuel lines (14) to the fuel pressure regulator with banjo bolts M10 (18) and new sealing rings 10x14 (19) on both sides. Tightening torque 15 Nm (133 in.lb).



See Chapter 73-00-00 of the latest Maintenance Manual Heavy for the respective engine type.

NOTICE

When fitting fuel lines, support them adequately to avoid strain or additional load.

d06767.fm

PRELIMINARY

SERVICE BULLETIN

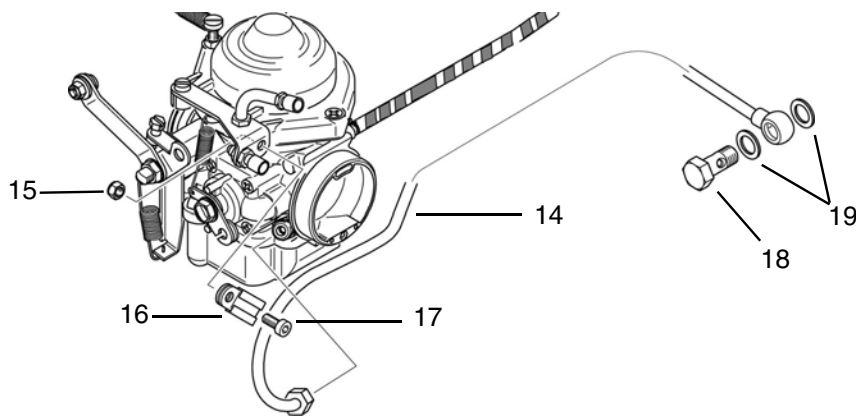

- 14 Fuel line
- 15 Lock nut M5
- 16 Cable clamp
- 17 Allen screw M5x12
- 18 Banjo bolt M10
- 19 Sealing rings 10x14

Fig. 9

AE_912_0216

Engine type 914 Series

3.3) Finishing work

- Restore aircraft to original operating configuration
- Connect negative terminal of aircraft battery

3.4) Test run

Conduct test run.



See Chapter 12-20-00 of the latest Maintenance Manual Line for the respective engine type.

PRELIMINARY

SERVICE BULLETIN

3.5) Summary

These instructions (section 3) have to be followed in accordance with the deadlines specified in section 1.5.

The execution of the mandatory Service Bulletin must be confirmed in the logbook.

| A revision bar outside of the page margin indicates a change to text or graphic.

Translation into other languages might be performed in the course of language localization but does not lie within ROTAX® scope of responsibility.

In any case the original text in English language and the metric units are authoritative.

3.6) Inquiries

Inquiries regarding this Service Bulletin should be sent to the ROTAX® Authorized Distributor of your area.

A list of all ROTAX® Authorized Distributors or their independent Service Centers is provided on www.flyrotax.com.

NOTE: The illustrations in this document show the typical construction. They may not represent full detail or the exact shape of the parts which have the same or similar function.
Exploded views are **not technical drawings** and are for reference only. For specific detail refer to the current documents of the respective engine type.

PRELIMINARY

d06767.fm